

JK MATERIALS CO., LTD

ADDRESS: 92A-94 ĐƯỜNG BẠCH ĐẰNG, PHƯỜNG 2, QUẬN TÂN BÌNH, THÀNH PHỐ HỒ CHÍ MINH
PHONE/ZALO/WHATSAPP/WECHAT: +84 985359913
EMAIL: JK MATERIALSCO@GMAIL.COM



A210 Series Slim Aluminium Door Lock

5 ways Unlock

- Fingerprint Unlock**
- password Unlock**
- IC Card Unlock**
- TT-Lock Unlock**
- Key Unlock**

Parameters :

- Semi-conductor fingerprint sensor, stable and 360 degree recognition
- Work with fingerprint, passcode, IC card and mechanical key
- Support BLE app and Wi-Fi gateway for easy management
- 304# stainless steel lock panel and handle
- Mirror polish treatment on the bevel side for elegant design
- Free handle with patent clutch inside, pull up the handle to activate the deadbolt.
- Various mortises available(35/85,45/85,50/85,60/85,70/85)
- Widely used for aluminum door or swing door (hook type optional).





Suitable for outdoor

A200 F

Slim Aluminium door lock

Fit for xingfa door



TTLock APP

A200F-SN



Silver

A200F-BN



Black

A220F-BN (R)



Round handle



Bluetooth 4.1



Fingerprint



Password



RF Card



Mechanical Key



Touch Keypad



Random Password



Voice Indicator



User Management



Low Battery Alarm

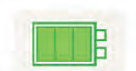

Emergency Power Support



Safe Handle



Reversible Handle



Double Latch



Double Hook

Material	Zinc Alloy, ABS	User Capacity	100 (FP) + 150 (PW) + 200 (CARD)
Power	6V (Alkaline AAA battery x 4)	Card	S50 (13.56MHz)
Battery Life Time	3,000-4,000 times	Packing	
Mechanical Key	2 keys	Carton loading	10 sets
Fingerprint Sensor	Semiconductor Sensor	Carton weight	24.3 kg
Password	6-10 Digits	Carton volume	49.5*45.0*39.5cm

A208 F IPX5 waterproof

Slim Aluminium door lock

Silver



A208F-SN

Rose gold















A208F-RG

Black

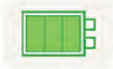

A208F-BN

-  Bluetooth 4.1
-  Fingerprint
-  Password
-  RF Card
-  Mechanical Key
-  Touch Keypad
-  Random Password
-  Voice Indicator
-  User Management
-  Low Battery Alarm
-  Emergency Power Support
-  Safe Handle
-  Reversible Handle



Material	Aluminium alloy, ABS	User Capacity	100 (FP) + 199 (PW) + 199 (CARD)
Power	6V (Alkaline AAA battery x 4)	Card	S50 (13.56MHz)
Battery Life Time	3,000-4,000 times	Packing	
Mechanical Key	2 keys	Carton loading	6 sets
Fingerprint Sensor	Semiconductor Sensor	Carton weight	16.15 kg
Password	6-10 Digits	Carton volume	54*39.5*28.5cm

K710

Lever Fingerprint Lock

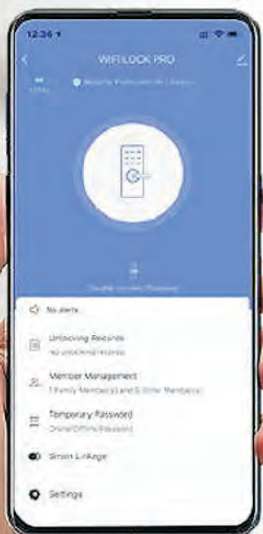

Silver



Black

TTLOCK BLUETOOTH SOLUTION TUYA WIFI&BLE SOLUTION



Parameters :

- Semi-conductor fingerprint sensor, stable and 360 degree recognition
- Work with fingerprint, passcode, IC card and mechanical key
- Support BLE app and Wi-Fi gateway for easy management
- 304# stainless steel lock panel and handle
- Mirror polish treatment on the bevel side for elegant design
- Free handle with patent clutch inside, pull up the handle to activate the deadbolt.
- Various mortises available(35/85,45/85,50/85,60/85,70/85)
- Widely used for aluminum door or swing door (hook type optional).

Design for different door type



Aluminum Door

Wooden Door

Metal Door

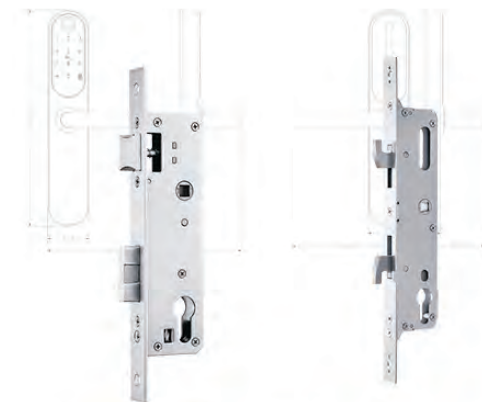

Double Latch

Double Hook



T01 F

Slim Aluminium Door Lock

6 ways Unlock

Fingerprint
Unlock

password
Unlock

IC Card
Unlock

TT-Lock
Unlock

Wireless
Remote
(Optional)

Key
Unlock

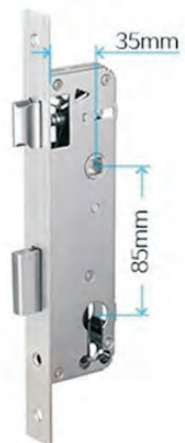

Semi-conductor Fingerprint | APP Unlock | Pure 304# Stainless Steel

Waterproof	YES
Material	304# stainless steel panel/handle
Version	TTlock
Battery	4pcs AAA alkaline battery
Mortise	35/85, 40/85, 55/72
Packing	10 pcs/CTN

S1 Electronic Cylinder



Support manual key, IC card, fobs and your fingerprint for one smart access control solution



Suitable for most europe doors, easy for update to smart lock



This gives users and system administrators the capability to send or receive a mobile key to open any door or gate with TUYA APP

Parameter:

Dimension	42X42mm
Batteries	1xCR123A (Alkaline)
Material	Aluminum alloy/Brass
Installation	Intermediate;tools required(Included)
Unlock Way	App, Fingerprint, Keycard, Manual key
Protection Rating	IP5x(dust and splash proof)
Battery Backup Port	1xMicro-Type-C charging port
Door thickness:	35-45mm

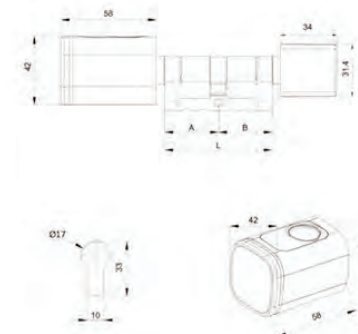

▲ Replace ball lock - single lock tongue version

single lock
tongue version



Fission
installation



SMART LOCK T3

Fingerprint lock

Office/home/apartment

Multi-function Full coverage



T3



* Tuya system and TTLock system - two options for choice



Black color



Silver color

Parameter:

Material:	Aluminium alloy
Surface Finishing:	Electroplated
Fingerprint reader area:	13.2*13.2mm
Unlock Way:	App, Password, Fingerprint or Key
App Name:	TTLock App or Tuya App
Support System:	IOS7.0 or Android 4.4 or above
Power Supply:	4pcs AAA alkaline batteries
Mortise:	Adjustable single latch (60/70mm) or double mortise
Color:	Black or silver
Working Temperature:	-20~70 degree
Apply Door Thickness:	35~55mm
USB Back Up Power:	Yes
Application:	Office, Apartment, Home, School
Applicable For:	Wooden or Metal door



TTLock Version



Tuya Bluetooth Mesh Version



Compatible with Amazon Alexa



Compatible with Google Home

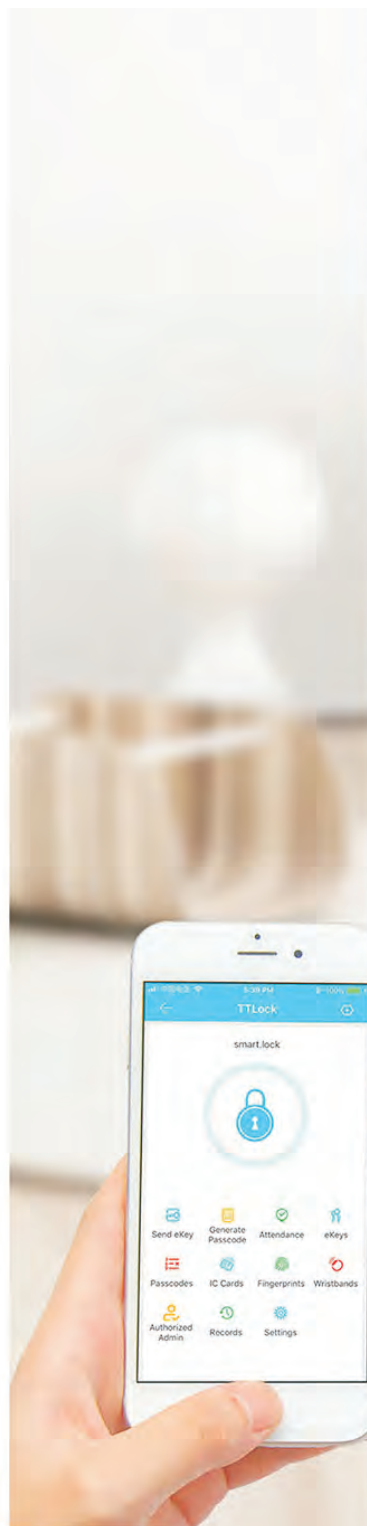

T5

Lever fingerprint lock

A233 series Fingerprint Lock



Parameters :

- Patent design, designed by Italy engineer
- Aluminum alloy materil with electrophoretic treatment
- Satin polish or black nickel treatment
- Acrylic reader with 12 digits passcode
- Work with BLE app, passcode, IC card and mechanical key
- Emergency manual key for back up use
- Suitable for 60/70 adjustable latch bolt or 5050/5572/4585 and KS mortise
- Perfect choice to replace the old locks without extra holes.
- Widely used for wood door or replace the knob locks.



Password
Unlock



IC card
Unlock



Fingerprint
Unlock



APP
Unlock



Key
Unlock

TTLOCK BLUETOOTH SOLUTION TUYA WIFI&BLE SOLUTION



Powered by
Tuya
Tuya WiFi
Solution



TTLock
App

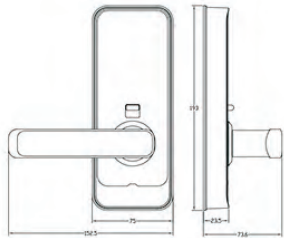
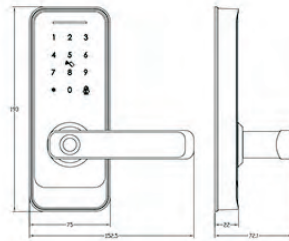

A233 series Fingerprint Lock



A270

TECHNOLOGY CHANGES THE LIFE



Fingerprint lock Interior Smart Lock

INTRODUCTION

- Smart BLE Digital Fingerprint Lock
- Work with proximity card
- Aluminum alloy material with electrophoretic treatment
- Black oxidation treatment
- Available for 60/85,55/72 mortise or single latch
- Work with alkaline battery
- Emergency key for backup use
- 300,000 times life test
- Work with bluetooth technology
- Support remote passcode change
- Available for WIFI router for remote management (optional)

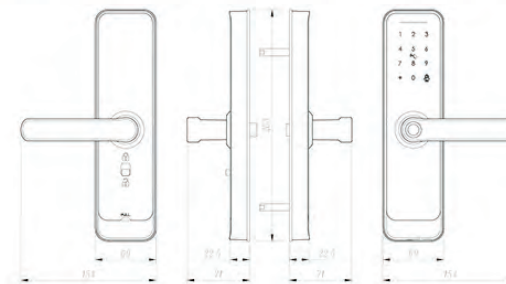

TTLOCK BLUETOOTH SOLUTION TUYA WIFI&BLE SOLUTION



Tuya WiFi Solution

TT Lock App



Password Unlock



IC card Unlock



Fingerprint Unlock



APP Unlock



Key Unlock

Fingerprint door lock



Optional
Door viewer



H01F-BN

H01FC-BN

- Bluetooth 4.1
- Fingerprint
- Password
- RF Card
- Mechanical Key
- Touch Keypad
- Random Password
- Voice Indicator
- User Management
- Low Battery Alarm
- Emergency Power Support
- Safe Handle
- Reversible Handle



Success

Fail

Material	Aluminium alloy, Acrylic	User Capacity	10 admin + 190 normal users
Power	6V (Alkaline AA battery x 4)	Card	S50 (13.56MHz)
Battery Life Time	3,000-4,000 times	Packing	
Mechanical Key	2 keys	Carton loading	10 sets
Fingerprint Sensor	Semiconductor Sensor	Carton weight	20.5 kg
Password	6-24 Digits	Carton volume	58.0*41.5*34.5cm

A260 series Fingerprint Lock



Black



Satin Nickel

Parameters:

- Smart BLE Digital Fingerprint Lock
- Work with proximity card
- Aluminum alloy materil with electrophoretic treatment
- Black oxidation treatment
- Available for 60/85,55/72 mortise or single latch
- Work with alkaline battery
- Emergency key for backup use
- 300,000 times life test
- Work with bluetooth technology
- Support remote passcode change
- Available for WIFI router for remote management(optional)

TTLOCK BLUETOOTH SOLUTION TUYA WIFI SOLUTION

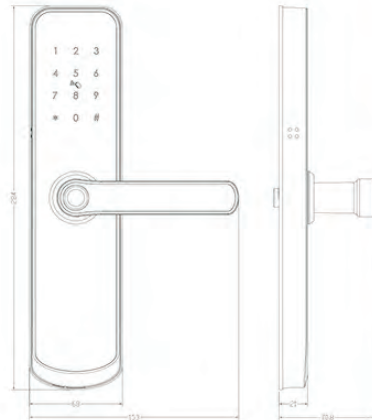

A260 series Fingerprint Lock



A230N series Fingerprint Lock



Black



Satin Nickle

Parameters :

- Patent design, designed by Italy engineer
- Aluminum alloy materi with electrophoretic treatment
- Satin polish or black nickel treatment
- Acrylic reader with 12 digits passcode
- Work with BLE app, passcode, IC card and mechanical key
- America type cylinder with high security mechanical keys
- Auto lock and auto unlock with 60/70 adjustable deadbolt
- Perfect choice to replace the old locks without extra holes.
- Widely used for wood door or replace the knob locks.

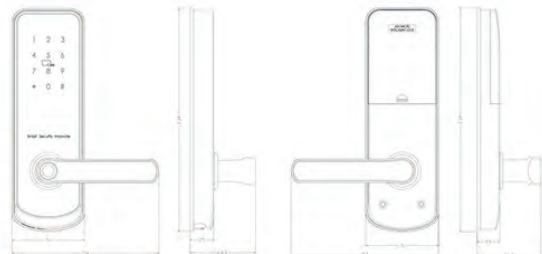

TTLOCK BLUETOOTH SOLUTION TUYA WIFI SOLUTION



A230N series Fingerprint Lock



Handle with sensitive
fingerprint scanner



≤ 0.5 seconds
unlock



Convenient APP
management



Compatible with
5050 / 5072 / 4585
/6052 mortise etc



A290 series

Fingerprint Lock

Parameters :

- Patent design, designed by Italy engineer
- Aluminum alloy materil with electrophoretic treatment
- Black or satin nickle treatment
- Acrylic reader with 12 digits passcode
- Work with BLE app, passcode, IC card and mechanical key
- High security cylinder and Micro-USB power charge for backup
- Auto lock and auto unlock with 60/70 adjustable deadbolt
- Perfect choice to replace the old locks without extra holes.
- Widely used for wood door or replace the knob locks.

TTLOCK BLUETOOTH SOLUTION TUYA WIFI SOLUTION



Black



Silver

A290 series

Fingerprint Lock



Fingerprint



APP



Password



IC card



Key



Two color



black

red bronze-coloured

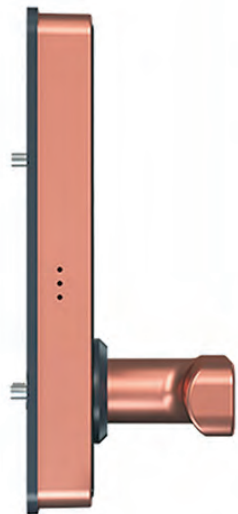

Smart lock

Model:T2



Unlocking via APP



Unlocking via
fingerprint



Unlocking via
time-limited passcode



Unlocking via
IC card



Unlocking via
mechanical key



E300F Series

BLUETOOTH DIGITAL LOCK

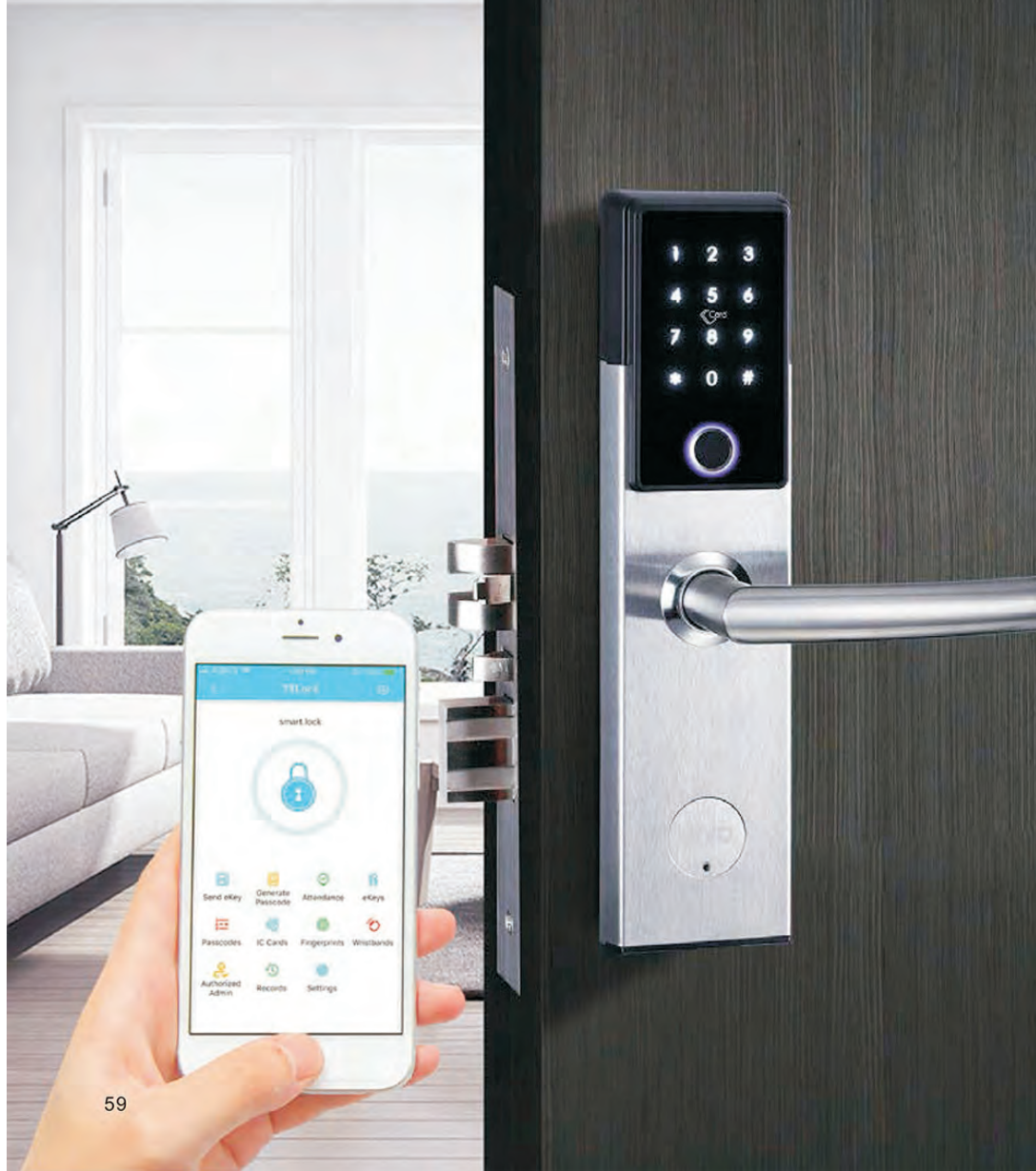

E300F Series

BLUETOOTH DIGITAL LOCK

Parameters :

- Classical design Bluetooth lock
- App, Password, Fingerprint, Card, Wristband or Key
- 304# stainless steel material for lock handle and cylinder cover
- Work with ANSI mortise with 500000 times lifespan
- Free handle design to avoid the artificial damage
- Widely used to replace the apartment or office
- Available to change to Bluetooth hotel lock for hotel use.
- Support BS system with card encoder for management(Hotel version only)
- Emergency mechanical key, no worry for the unlock if there is no power

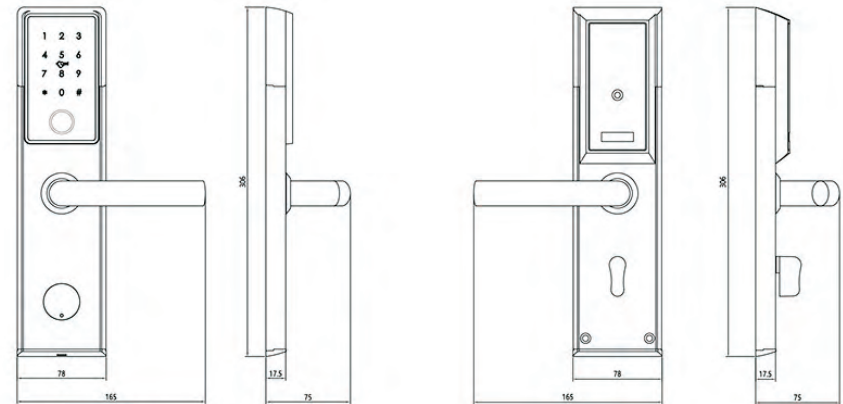

A220 Series Deadbolt Lock



Black



Satin Nickle

TTLOCK BLUETOOTH SOLUTION TUYA WIFI&BLE SOLUTION

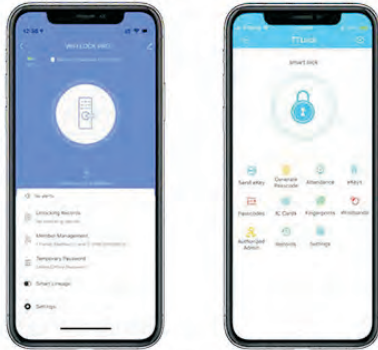

Parameters:

- Patent design, designed by Italy engineer
- Aluminum alloy materiil with electrophoretic treatment
- Satin polish or black nickel treatment
- Acrylic reader with 12 digits passcode
- Work with BLE app, passcode, IC card and mechanical key
- America type cylinder with high security mechanical keys
- Auto lock and auto unlock with 60/70 adjustable deadbolt
- Perfect choice to replace the old locks without extra holes.
- Widely used for wood door or replace the knob locks.

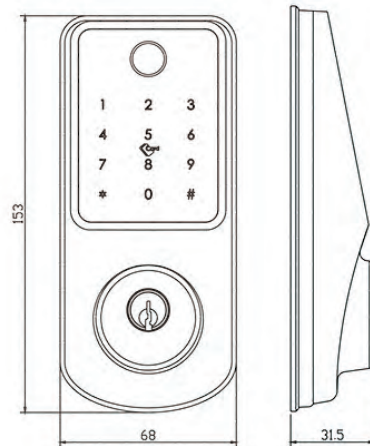

A220 Series Deadbolt Lock





Scenario 1

Scenario 2

Deadbolt lock



Model: T1

6 WAYS TO UNLOCKS

- Unlocking via BLE
- Unlocking via fingerprint
- Unlocking via time-limited passcode
- WIFI available (with gateway)
- Unlocking via IC card
- Unlocking via mechanical key

Two color



black



silvery



E908 Series

TECHNOLOGY CHANGES THE LIFE



Fingerprint lock Interior Smart Lock

INTRODUCTION

- Smart Digital Fingerprint Lock
- Work with proximity card
- Aluminum alloy material, tempered glass panel
- Black Nickel treatment
- Available for 6068 security mortise or europe 6085/5572 mortise
- Work with alkaline battery
- Emergency key for backup use
- 300,000 times life test
- Work with TTLOCK or Tuya Wifi or Zigbee technology
- Support remote passcode change
- Available for WIFI router for remote management (optional)



TUYA WIFI SOLUTION & TTLOCK SOLUTION

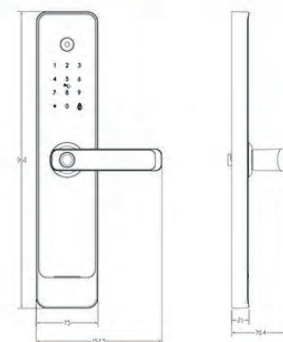

Digital door viewer



Password Unlock



IC card Unlock



Fingerprint Unlock



APP Unlock

E902F Series Bluetooth Hotel Lock



 **TTHotel APP**
management

 **TTLock APP**
For home security/ Office/
rental management

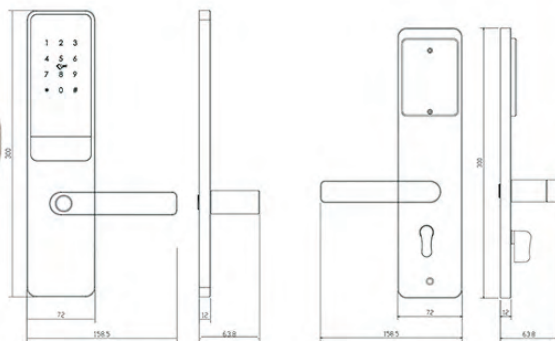

E902F Series BLUETOOTH DIGITAL LOCK

Parameters:

- Classical design Bluetooth lock
- App, Password, Fingerprint, Card, Wristband or Key
- Solid Aluminium material for panel and handle
- Work with 6068 mortise with 500000 times lifespan

- Free handle design to avoid the artificial damage
- Widely used to replace the apartment or office
- Available to change to Bluetooth hotel lock for hotel use.
- Support BS system with card encoder for management(Hotel version only)
- Emergency mechanical key, no worry for the unlock if there is no power

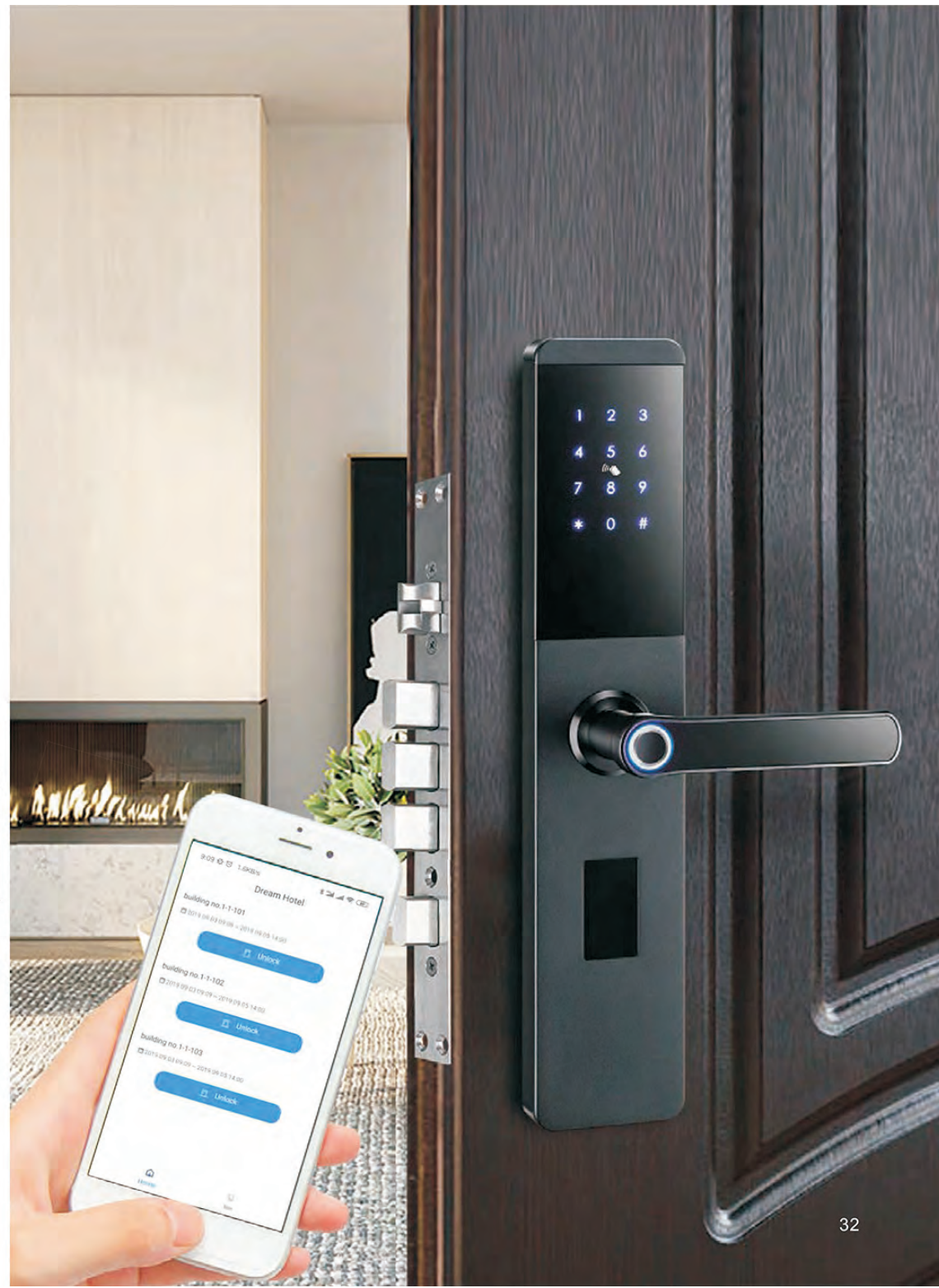











E907

TECHNOLOGY CHANGES THE LIFE



Fingerprint lock Interior Smart Lock

INTRODUCTION

-  Smart Zigbee Digital Fingerprint Lock
-  Work with proximity card
-  Aluminum alloy materil with electrophoretic treatment
-  Black oxidation treatment
-  Available for 6068 mortise or single latch
-  Work with alkaline battery
-  Emergency key for backup use
-  300,000 times life test
-  Work with bluetooth technology
-  Support remote passcode change
-  Available for WIFI router for remote management (optional)



Black



Red Bronze

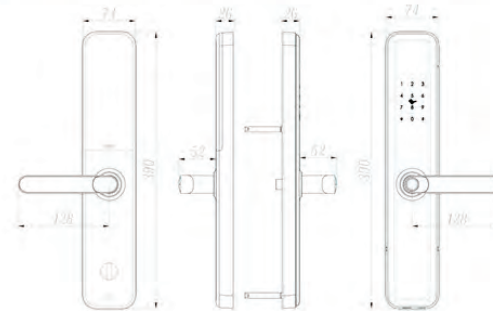

Password
Unlock



IC card
Unlock



Fingerprint
Unlock



APP
Unlock



Key
Unlock



X-03



TUYA wifi solution



Center Distance: 52mm;
Backset: 60mm



Fingerprint



Pasword



Card



Remote (option)



Phone app (option)



Key



Anti-pick alarm



C grade cylinder



Phone setting



Low power alarm



Usb charger



User management

Material: Aluminum alloy

User: 300 (FP + Code + Card)

Battery: 4pcs AA batteries

Packing: 4 pcs/ ctn
54.0 * 42.5 * 23.5 cm/ctn
18kg/ctn

X3-PLUS



TT Lock App

TUYA wifi solution

5 ways to unlock:

- * Phone app
- * Fingerprint
- * PIN Code,
- * MF Card,
- * Mechanical Key

Easy set up

Do not need home gateway, you can easily achieve the intelligence control of home appliance. Simple operation, easy to use. 2.4Ghz protocol is more stable faster and more convenient.



TECHNICAL SPECIFICATION:

Material: Aluminum alloy

Available color: Satin Nickel, Black Nickel

Panel Sizes: L 300(mm)*W 68(mm)

Unlock method: WIFI, M1 Card, Pass code, Fingerprint, Wristband or key

App name: Tuya app or tt lock app

Support system: IOS7.0 or Android 4.4 or above

Batteries life: 10000 times normal open(12 months)

Power supply: DC6V, 4pcs alkaline batteries

Static current: 45Ua

Dynamic current: <200Ma

Unlock time: 1-1.5 seconds





TUYA wifi solution

Y1 series



Fingerprint



Pasword



Card



Remote (option)



Phone app (option)



Key



Anti-pick alarm



C grade cylinder



Phone setting



Low power alarm



Usb charger



User management



Y1-H



Y1-B

Material: Aluminum alloy

Solution: Tongxin

Panel: 3D Curved surface toughened glass full screen

User: Less than 300

Surface technology: Spray paint

Battery: 4.5V - 6.5V 4pcs AA batteries

Product size: 365mm * 75mm * 24mm

Works with
TTLock APP

B2



Bluetooth 4.1



Fingerprint



Password



RF Card



Mechanical Key

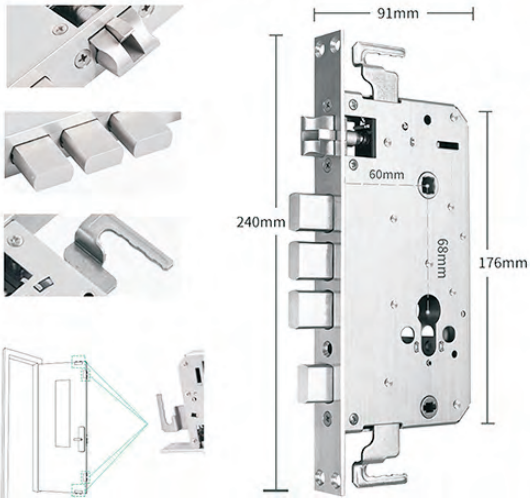

High security mechanism



Anti friction latch & bolt
100,000 cycling test



Anti corrosion
48 hrs salt fog test



Quiet and durable





TUYA wifi solution

3D Face Recognition



Fingerprint



Password



Card



Remote (option)



Phone app (option)



Key



Anti-pick alarm



C grade cylinder



Phone setting



Low power alarm



Usb charger



User manage

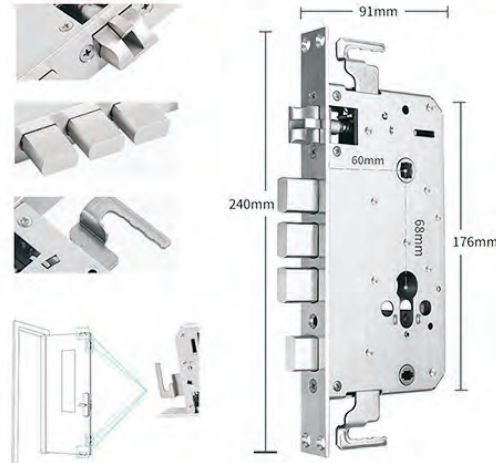

Center Distance: 68mm;
Backset: 60mm



F1

6 in 1 unlock ways

1. Face identification
2. TUYA app
3. Fingerprint unlock
4. Password unlock
5. Mf Card unlock
6. Mechanical key unlock

Inside with anti-peel camera (Cat eye)



Fully automatic lock X2



TUYA wifi solution



Center Distance: 68mm; Backset: 60mm

Finish: ● BK

Material	Aluminum Alloy, ABS	Card	S50 (13.56 MHz)
Mortise	Center Distance: 68mm; Backset: 60mm	Mechanical Key	2 Keys
Applied Door Thickness	40-50mm	User Capacity	300 (FP/PW/CARD)
Power	7.4V (4200 mAh lithium battery)		
Battery Life Time	3,000-4,000 times	Packing information	
Emergency power	Micro-USB	Carton Dimensions	47.0*47.0*32.0 cm
Operating Temperature	-15-55°C	Carton Weight	16kg
Fingerprint Sensor	Semiconductor Sensor	Carton Loading	4 Sets
Password	6-8 Digits		



Fully automatic lock Y6



TUYA wifi solution



- Material:** Aluminum alloy
- User:** 300 (FP + Code + Card)
- Battery:** Built-in Lithium batteries
- Fingerprint:** Semi-conductor
- Option:** Tuya wifi
- Option:** Anti-peel version

Fingerprint	Password	Card
Remote (option)	Phone app (option)	Key
Anti-pick alarm	C grade cylinder	Phone setting
Low power alarm	Usb charger	User manage

Fully automatic lock



DF2

TUYA wifi solution



Center Distance: 68mm;
Backset: 60mm

- Material:** Aluminum alloy
- User:** 300 (FP + Code + Card)
- Battery:** Built-in Lithium batteries
- Fingerprint:** Semi-conductor
- Option:** Tuya wifi
- Option:** Anti-peel version

Fingerprint	Password	Card
Remote (option)	Phone app (option)	Key
Anti-pick alarm	C grade cylinder	Phone setting
Low power alarm	Usb charger	User manage

S100 Series

PATENT DESIGN SPLIT LOCK

PATENT NO.:ZL201630283587. 1



S100-GG Bright Golden

SPLIT HOTEL LOCK

Pure 304# stainless steel material
Die casting 304# mortise latch and deadbolt
Hidden cylinder ensure the security
Imported PC material for the reader
Can be change to different h

S100 SERIES



S100-CR Satin Finish

S100-BN Black Nickel

INTRODUCTION

- 304 304#stainless steel reader,handle and collar.
- Backup mechanical key, brass +ABS.
- Proximity RF technology,fast and stable.
- with die casting stainless steel latch and deadbolt.
- Low power alarm, guest card can still open the door.
- User-friendly software, easy to use and management.

PARAMETERS

Mechanism:304# reader,front/back panel and handle
Unlock way: Mifare card or mechal key
Power supply: 4xAA alkaline battery(DC6v)
Static current: 25uA
Dynamic current:< 150mA
Working temperature:-20-45 degree
Working humidity: 20-95%
Available door thickness: 40-65mm
Suggest usage: wood door

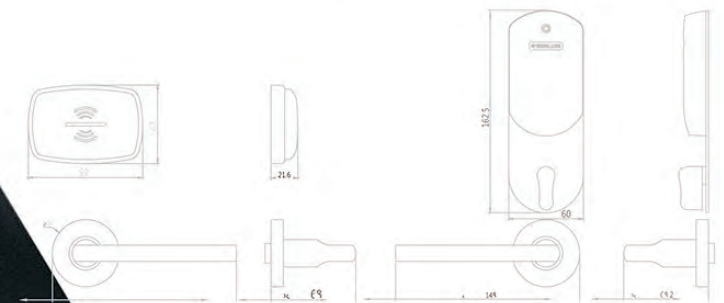

S170 series

SPLIT HOTEL LOCK



INTRODUCTION

- zn** Material: Zinc alloy handle and rosette
- key** Emergency cylinder hidden inside the handle
- RFID** Proximity RFID technology, fast and durable
- LED** LED indicator around the lock reader.
- battery** Special design for the hidden battery and pcb inside the mortise
- bluetooth** Support bluetooth technology with mobile access

PARAMETERS

#5 Zinc alloy handle, CNC aluminum reader
Unlock way: Mifare card or mechanical key
Power supply: 4xAA alkaline battery (DC6v)
Static current: 25uA
Dynamic current: < 150mA
Working temperature: -20~45 degree
Working humidity: 20~95%
Available door thickness: 40~65mm
Suggest usage: wood door

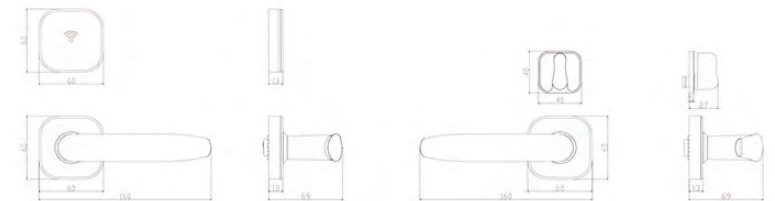

S180 series

PATENT DESIGN

SPLIT LOCK



SPLIT HOTEL LOCK

Pure 304# stainless steel material
 CNC made reader cover with mirror finish
 Imported leather handle with solid structure
 Die casting 304# mortise latch and deadbolt
 Hidden cylinder and pcb to ensure the security
 Imported PC material for the reader
 Free to change to different handles

S180 Series



S180-CR Mirror Finish

S180-SS Stainless

PARAMETERS

Mechanism: 304# reader, front/back panel and handle
 Available to choose leather handle with solid structure
 Unlock way: Mifare card or mechanical key
 Power supply: 4xAA alkaline battery (DC6v)
 Static current: 25uA
 Dynamic current: < 150mA
 Working temperature: -20~45 degree
 Working humidity: 20~95%
 Battery life: Normal open: 15000 times
 Low power alarm: when power is less than 4.8v, there is di-di-di beep, then you can still open 150 times.
 Audit trial: 990 latest records include the mechanical key
 Available door thickness: 40~65mm
 Suggest usage: wood door

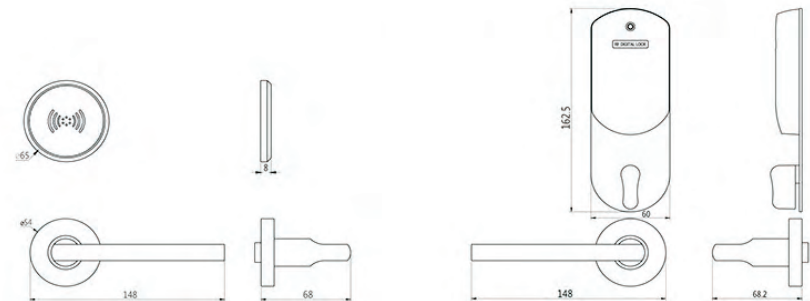



S190 series







S190-BN



S190-PW

INTRODUCTION

-  Material: Zinc alloy handle and rosette
-  Emergency cylinder hidden inside the handle
-  Proximity RFID technology, fast and durable
-  LED indicator around the lock reader.
-  Special design for the hidden battery and pcb inside the mortise
-  Support bluetooth technology with mobile access

PARAMETERS

#5 Zinc alloy handle, CNC aluminum reader
 Unlock way: Mifare card or mechanical key
 Power supply: 4xAA alkaline battery(DC6v)
 Static current: 25uA
 Dynamic current: < 150mA
 Working temperature: -20~45 degree
 Working humidity: 20~95%
 Available door thickness: 40~65mm
 Suggest usage: wood door

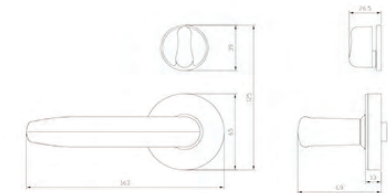
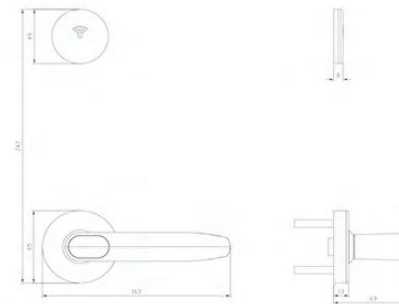



C300 Series
CLASSICAL HOTEL LOCK (RFID)

C300 Series



C300-GG PVD Golden



C300-SS Satin Finish

PARAMETERS

Mechanism: 304# front/back panel and handle
 304# cylinder cover and handle collar ensure the use under high humidity area
 Unlock way: Mifare card or mechanical key
 Power supply: 4xAAA alkaline battery(DC6v)
 Static current: 25uA
 Dynamic current:< 150mA
 Working temperature:-20~45 degree
 Working humidity: 20~95%
 Battery life: Normal open: 15000 times
 Low power alarm: when power is less than 4.8v, there is di-di-di beep, then you can still open 150 times.
 Audit trial: 990 latest records include the mechanical key
 Available door thickness: 30~65mm
 Suggest usage: wood door

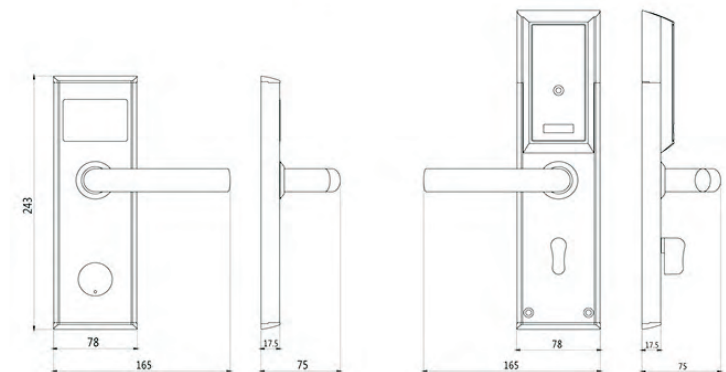



E301 Series

CLASSICAL HOTELL LOCK(RFID)



E301 Series

CLASSICAL HOTELL LOCK(RFID)

Parameters:

- Classical RFID Hotel Lock
- 304# stainless steel panel and handle, anti-rust
- Proximity card technology, fast and reliable
- Sliding cylinder cover for easy use
- Work with ANSI standard mortise, stable and reliable
- Support Bluetooth system for management
- Emergency mechanical key for backup use
- Integrated with Opera PMS system, suitable for high class hotels



304# stainless steel reader, handle and collar.



Backup mechanical key, brass +ABS.



Proximity RF technology, fast and stable.



with die casting stainless steel latch and deadbolt.



Low power alarm, guest card can still open the door.



User-friendly software, easy to use and management.

E300 Series
CLASSICAL HOTEL LOCK (RFID)



E300 SERIES



E300-GG PVD GOLDEN

E300-BN Black Nickel

E300-SS Satin Finish

PARAMETERS

Mechanism: 304# front/back panel and handle
 304# cylinder cover and handle collar ensure the use under high humidity area
 Unlock way: Mifare card or mechanical key
 Power supply: 4xAA alkaline battery(DC6v)
 Static current: 25uA
 Dynamic current: < 150mA
 Working temperature: -20~45 degree
 Working humidity: 20~95%
 Battery life: Normal open: 15000 times
 Low power alarm: when power is less than 4.8v, there is di-di-di beep, then you can still open 150 times.
 Audit trial: 990 latest records include the mechanical key
 Available door thickness: 30~65mm
 Suggest usage: wood door

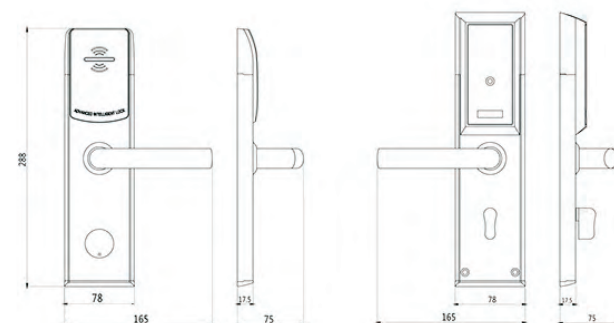

E200 Series

SLIM ELECTRONIC LOCK



E200-BN Black Nickel

E200 Series



E200-GG PVD Golden E200-SS Satin Finish

PARAMETERS

Mechanism: Arcylic reader, 304# front/back panel and handle
CNC made handle collar and 304# stainless steel battery box cover
ensure the use under high humidity area
Unlock way: Mifare card or mechanical key
Power supply: 4xAA alkaline battery(DC6v)
Static current: 25uA
Dynamic current:< 150mA
Working temperature:-20~45 degree
Working humidity: 20~95%
Battery life: Normal open: 15000 times
Low power alarm: when power is less than 4.8v, there is di-di-di beep,
then you can still open 150 times.
Audit trial: 990 latest records include the mechanical key
Available door thickness: 30~65mm
Suggest usage: wood door

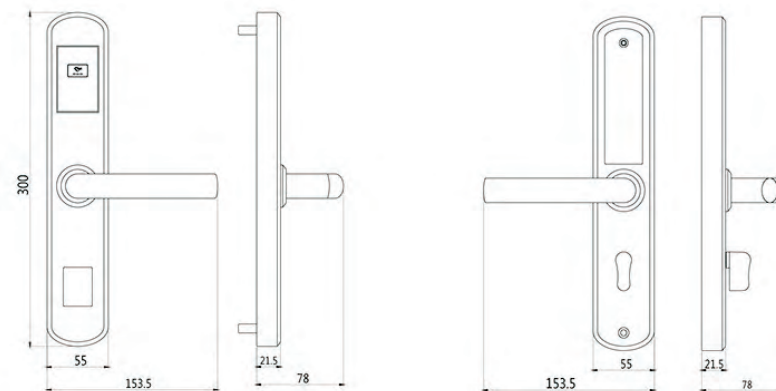

JK700 Series

EUROPE HOTEL LOCK

Europe Style Hotel Lock

Work with 60/85 mortise with panic function
Very convenient to replace the old locks
304# stainless steel material for long time use.
Patent handle structure, easy to change from left to right
With rubber gasket and sealed PCB to prevent the water

JK700 Series



JK700-SS Satin Finish

PARAMETERS

Mechanism: 304# reader, front/back panel and handle
Patent handle structure with bearing inside to ensure the smooth
Unlock way: Mifare card or mechanical key
Power supply: 4xAAA alkaline battery (DC6v)
Static current: 25uA
Dynamic current: < 150mA
Working temperature: -20~45 degree
Working humidity: 20~95%
Battery life: Normal open: 15000 times
Low power alarm: when power is less than 4.8v, there is di-di-di beep, then you can still open 150 times.
Audit trial: 990 latest records include the mechanical key
Available door thickness: 40~65mm
Suggest usage: wood door/aluminum door

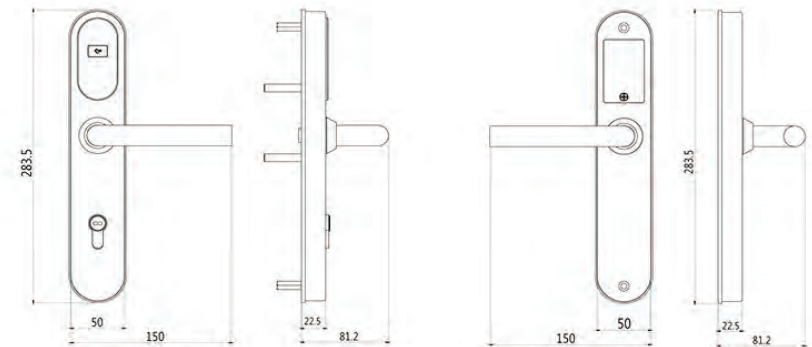

EU Mortise Series

A210 Series Slim Aluminium Door Lock

PARAMETERS

Mechanism: 304# reader, front/back panel and handle
Patent handle structure with bearing inside to ensure the smooth
Unlock way: Mifare card or mechanical key
Power supply: 4xAAA alkaline battery(DC6v)
Static current: 25uA
Dynamic current: < 150mA
Working temperature: -20~45 degree
Working humidity: 20~95%
Battery life: Normal open: 15000 times
Low power alarm: when power is less than 4.8v, there is di-di-di beep,
then you can still open 150 times.
Audit trial: 990 latest records include the mechanical key
Available door thickness: 40~65mm
Suggest usage: wood door/aluminum door

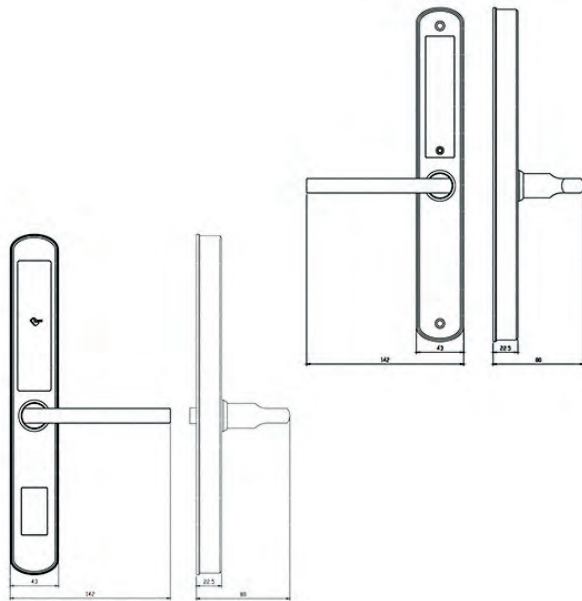



M800-BN(Black Nickel)



M800-SS(Stainless steel)

INTRODUCTION

Mechanism: Arcylic reader,304# front/back panel and handle
 304# stainless steel handle collar and battery box cover
 ensure the use under high humidity area
 Unlock way: Mifare card or mechical key
 Power supply: 4xAAA alkaline battery(DC6v)
 Static current: 25uA
 Dynamic current:< 150mA
 Working temperature: -20~45 degree
 Working humidity: 20~95%
 Battery life: Normal open: 15000 times
 Low power alarm: when power is less than 4.8v, thre is di-di-di beep,
 then you can still open 150 times.
 Audit trial: 990 latest records include the mechanical key
 Available door thickness: 30~65mm
 Software: Opera Fidelio integrated

DIMENSION

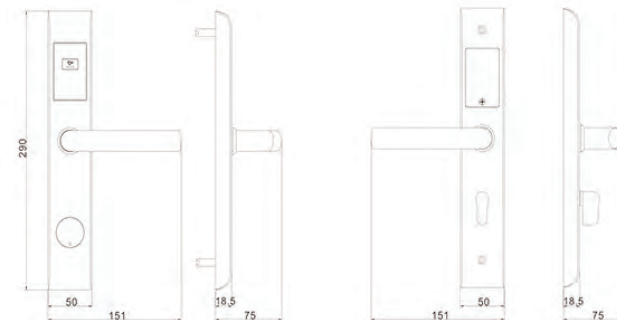

H160

H160 series

Lever Handle Hotel Lock

Parameters :

- Patent design for the RFID card hotel lock
- Concealed clutch and PCB inside the handle
- 5# zinc alloy lock handle and cylinder plate
- Bright chrome or black nickel polish treatment
- Free handle with patent clutch inside, pull up the handle to activate the deadbolt.
- Various mortises available(45/85,50/85,60/85,70/85)
- Widely used to replace the old Europe style mechanical locks
- Available to change to BLE fingerprint lock for office use.
- Work with IC card and mechanical key, with lock software for management

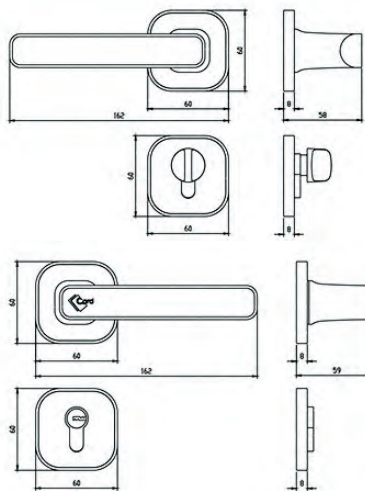

Apartment



Home stay



Hotel

Series Lever Handle Hotel Lock



S500 Series Luxury Hotel Lock

PROXIMITY ELECTRONIC LOCK

Luxury style lock for hotel/apartment use.
 With proximity technology, working frequency: 13.56MHZ.
 Standard treatment: Bright chrome and PVD golden.
 #5 Zinc alloy material for lock handle, panel, handle collar, good to use in high humidity area.
 Hidden cylinder design, provide you safety use.
 User-friendly software system, easy to install and maintain.
 With rustproof treatment, ensure long using life.
 Available to use on 30-60mm door.

S500 Series



S500-GG PVD Golden



S500-CR Bright Chrome

PARAMETERS

Mechanism: #5 Zinc reader, front/back panel and handle
 Hidden cylinder structure ensure the security
 Unlock way: Mifare card or mechanical key
 Power supply: 4xAA alkaline battery(DC6v)
 Static current: 25uA
 Dynamic current: < 150mA
 Working temperature: -20~45 degree
 Working humidity: 20~95%
 Battery life: Normal open: 15000 times
 Low power alarm: when power is less than 4.8v, there is di-di-di beep, then you can still open 150 times.
 Audit trial: 990 latest records include the mechanical key
 Available door thickness: 30-65mm
 Suggest usage: wood door

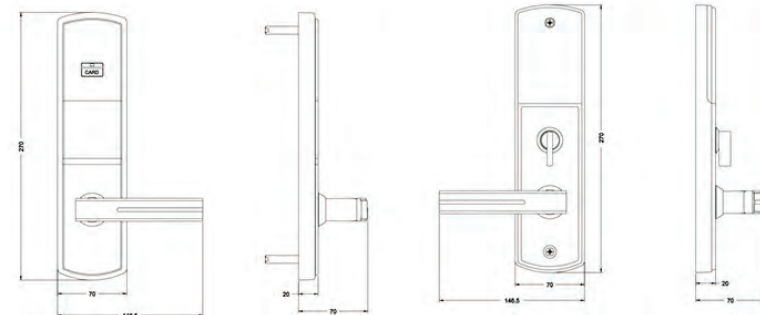



E900 SERIES

ALUMINUM HOTEL LOCK SERIES



E900 Series Aluminum Hotel Lock

Parameters :

- Mechanism: Acrylic reader, solid aluminum panel and handle and battery box cover ensure the use under high humidity area
- Unlock way: Mifare card or mechanical key
- Power supply: 4xAA alkaline battery(DC6v)
- Static current: 25uA
- Dynamic current: < 150mA
- Working temperature: -20~45 degree
- Working humidity: 20~95%
- Battery life: Normal open: 15000 times
- Low power alarm: when power is less than 4.8v, there is di-di-di beep, then you can still open 150 times.
- Audit trial: 990 latest records include the mechanical key
- Available door thickness: 30~65mm
- Suggest usage: wood door
- Software: Opera Fidello integrated

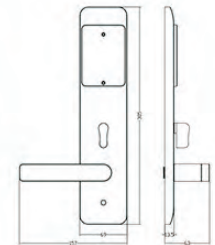
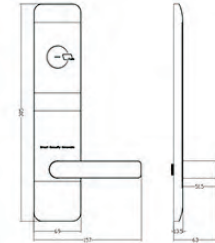

304

304#stainless steel reader, handle and collar.



Backup mechanical key, brass +ABS.



Proximity RF technology, fast and stable.



with die casting stainless steel latch and deadbolt.



Low power alarm, guest card can still open the door.



User-friendly software, easy to use and management.

E901 series Bluetooth Hotel Lock



E901-BN

E901-SS

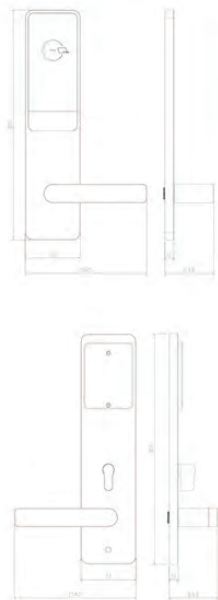

E901 series BLUETOOTH DIGITAL LOCK

Parameters :

- Classical design Bluetooth lock
- Unlock by Bluetooth APP/IC Card/Passcode or mechanical key
- Solid Aluminium material for panel and handle
- Work with 6068 mortise with 500000 times lifespan

- Free handle design to avoid the artificial damage
- Widely used to replace the apartment or office
- Available to change to Bluetooth hotel lock for hotel use.
- Support BS system with card encoder for management(Hotel version only)
- Emergency mechanical key, no worry for the unlock if there is no power

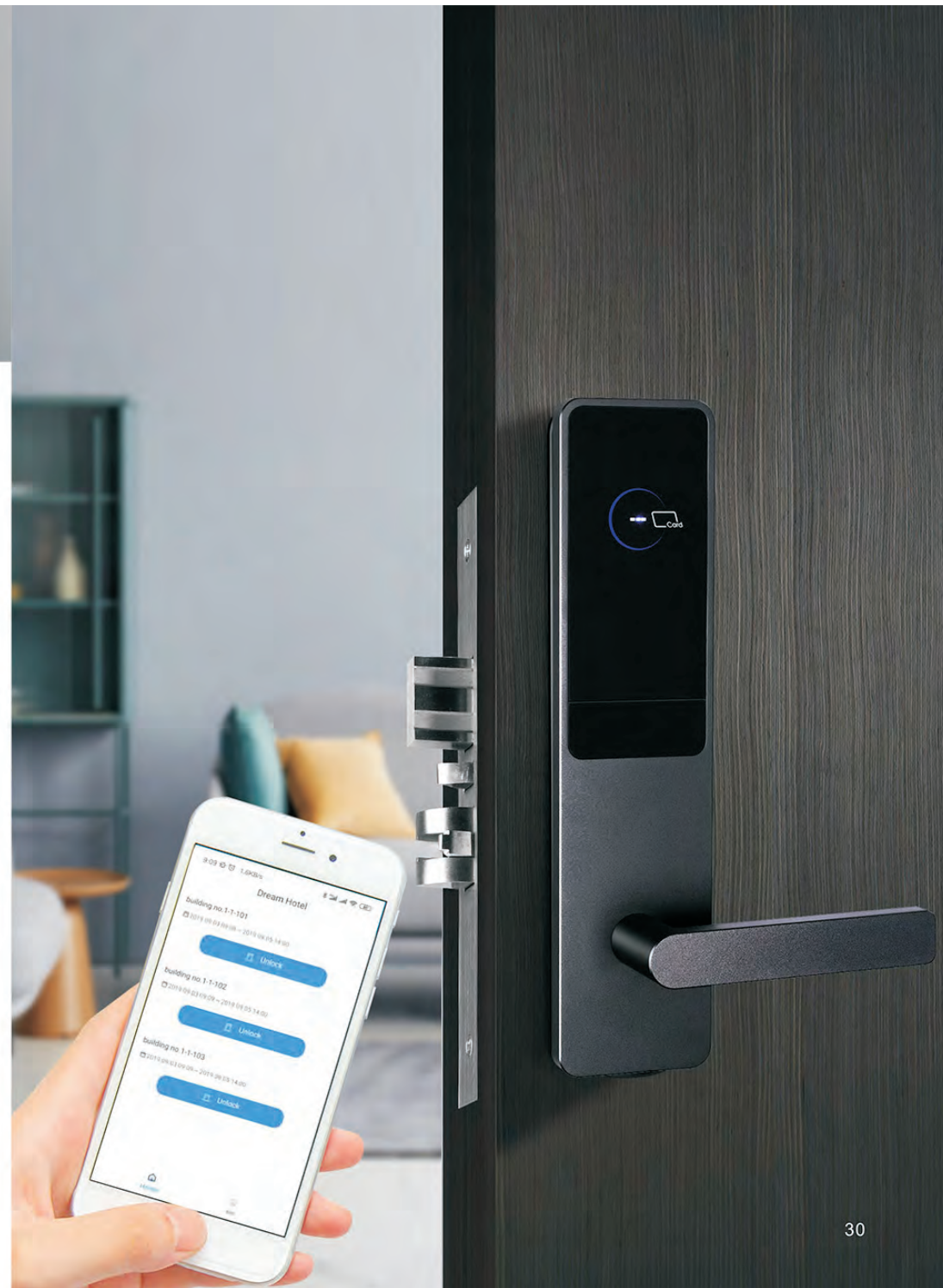

HOTEL LOCK SYSTEM



Computer: Memory:500GB above, hard disk suggested 2G above, USB port required.
 Software: Windows system, windows 7/8/10.
 Database: Windows Access / Microsoft SQL server 2008 above.
 Encoder: Read/write card and software registration.
 Door Lock: Installed on each room.
 LCD Handset: Configure room No.,adjust time, audit trial records etc.
 RF Card: Unlock the door lock.
 Printer: as request from the site.

LOCK SYSTEM ACCESSORIES

MCE02-17 CARD ENCODER

Technical Parameter

- Working voltage:DC5V
- Rated current:500mA
- Working humidity:RH 10%~90%
- working temperature:-20° C~55° C
- Reading speed:< 1 S
- Defect type: auto check

Specification

- Universal USB port, no need extra driver.
- Auto detect the card.
- Fast reading speed and stable to use
- Support one card system integration

PHD01-16 LCD HANDSET

Technical Parameter

- Working voltage: DC3V
- Static current: < 10 uA
- Working current: < 100mA
- Storage humidity: RH 5%~95%
- Working temperature:-25 ~ 70°C
- Reading speed: < 1 S
- Size: 177.6 x 85 x 30mm

Specification

- One station solution, no need special room setting card
- Fast and correct time adjustment
- Special system checking for hardware and firmware
- Easy to check the card information
- Convenient to check audit trial records
- Support checkout function,

HOTEL LOCK SYSTEM



Elevator Control

APP Unlock

Password Unlock

IC Card Unlock

3D face recognition



WIFI

Model: 928

Users: 1000
(Fingerprint + Code + Card=1000)

OEM screen: Yes

Glass door thickness: 10-12mm

Batteries: Lithium batteries

Fingerprint reader: Semi-conductor

Latch material: Stainless steel

Optional: TUYA version

* **Smart 3D face identity**

* **Tuya app**

* **Mechanical key unlock**

* **Clutch motor**

No need drilling the door



Fingerprint



Password



RF Card



Random Password



Touch Keypad



LED Display



User Management



Low Battery Alarm



Emergency Power Support



Auto Lock



Voice Indicator



Remote control



Model: 918



Fingerprint



Password



RF Card



Random Password



Touch Keypad



TT Lock



User Management



Low Battery Alarm



Emergency Power Support



Auto Lock



Voice Indicator



Remote control

Fingerprint Users: 100

Password Users: 500

IC card Users: 500

Glass door thickness: 10-12mm

Batteries: 4pcs AA batteries

Fingerprint reader: Semi-conductor

Latch material: Stainless steel

Packing : 10pcs/ ctn

Glass door lock



TTLock APP



Model: 899

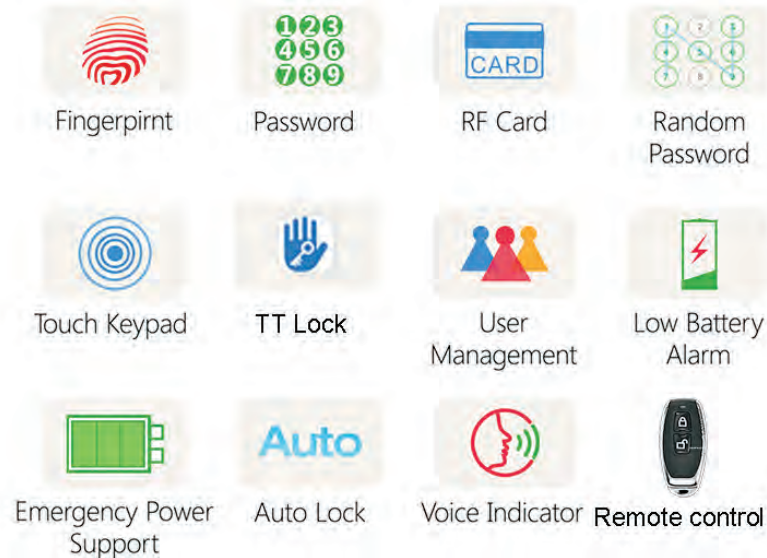

- Fingerprint Users: 100
- Password Users: 500
- IC card Users: 500
- Glass door thickness: 10-12mm
- Batteries: 4pcs AA batteries
- Fingerprint reader: Semi-conductor
- Latch material: Stainless steel
- Packing : 10pcs/ ctn (15.15kg)
- Carton : 49.0*48.5*25.0cm



Model: F6

GLASS DOOR LOCK

Model: 898

No need drilling the door

Suitable :

- Glass door
- Wooden door
- Fireproof door

Glass door with frame







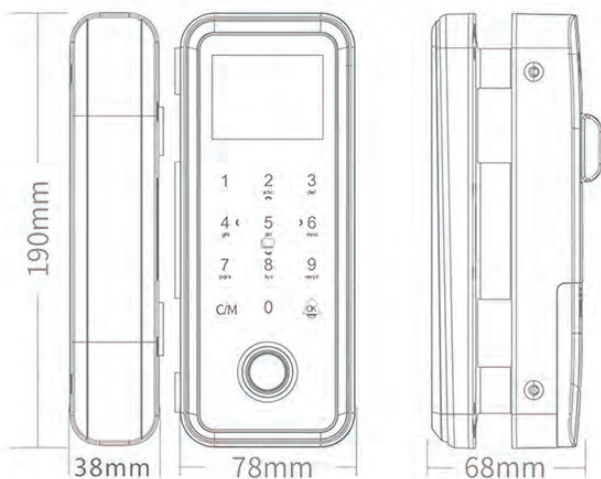





- Users:** 1000
(Fingerprint + Code + Card=1000)
- OEM screen:** Yes
- Glass door thickness:** 10-12mm
- Batteries:** 4pcs AA batteries
- Fingerprint reader:** Semi-conductor
- Latch material:** Stainless steel



Double Pole mortise















Double Hook mortise

- | | | | |
|--|--|--|--|
| 
Fingerprint | 
Password | 
RF Card | 
Random Password |
| 
Touch Keypad | 
LED Display | 
User Management | 
Low Battery Alarm |
| 
Emergency Power Support | 
Auto Lock | 
Voice Indicator | 
Remote control |

Glass door lock



Model: 911

-  Fingerprint
-  Password
-  RF Card
-  Random Password
-  Touch Keypad
-  Tuya wifi
-  User Management
-  Low Battery Alarm
-  Emergency Power Support
-  Auto Lock
-  Voice Indicator
-  Remote control

- Fingerprint Users: 100
- Password Users: 500
- IC card Users: 500
- Glass door thickness: 10-12mm
- Batteries: 4pcs AA batteries
- Fingerprint reader: Semi-conductor
- Latch material: Stainless steel
- Packing : 10pcs/ ctn (15.15kg)
- Carton : 49.0*48.5*25.0cm



Model: 916



Model: P330

- Fingerprint Users: 50
- Code Users: 1000
- Card Users: 1000
- OEM screen: Yes
- Glass door thickness: 10-12mm
- Batteries: 4pcs AA batteries
- Fingerprint reader: Semi-conductor
- Material: Plastic



No need drilling the door

 Fingerprint	 Password	 RF Card	 Random Password
 Touch Keypad	 LED Display	 User Management	 Low Battery Alarm
 Emergency Power Support	 Auto Lock	 Voice Indicator	 Remote control

K3 Smart Key Box



TTLock Version



Tuya Bluetooth Mesh Version



Compatible with Amazon Alexa



Compatible with Google Home



Use your type USB power bank to charge the lock to unlock

4 Ways unlock



Strong and Durable Body



Zinc alloy body, strong and durable. Withstand fall within 1 meter.



Could be used for outdoor, operation temperature ranges from -25°C-55°C (-13°F-131°F).



Min. 10,000 times lock & unlock lasts for 12 months.

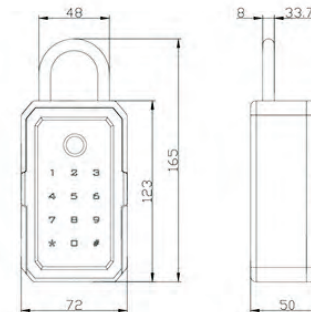

Intelligent

A keyless experience without replacing your existing lock. Simply install in a few minutes. Open Keybox via PIN code or Bluetooth. Use our App "Tuyasmart" or "TTLOCK" to unlock, share access, and see the access records.



A230P Bluetooth Digital Lock SERIES



A230P-BN(Black Nickel)



A230P-SS(Satin nickel)

INTRODUCTION

Smart Digital Lock

- 304# stainless steel material for handle, zinc alloy panel
- Die casting 304# stainless steel mortise latch and deadbolt
- Touchscreen keypad
- Work with passcode or card or wristband
- Bluetooth technology to unlock the door
- Support WIFI router to remote change the admin passcode
- No need front reception, save your labor cost and management
- Real time unlocking record in the mobile APP
- Passcode has time limit or times limit
- Support Ekey to unlock the door
- Support bracelet to unlock the door
- Support external power for supply
- Work with alkaline battery, 12 months battery life.

DIMENSION

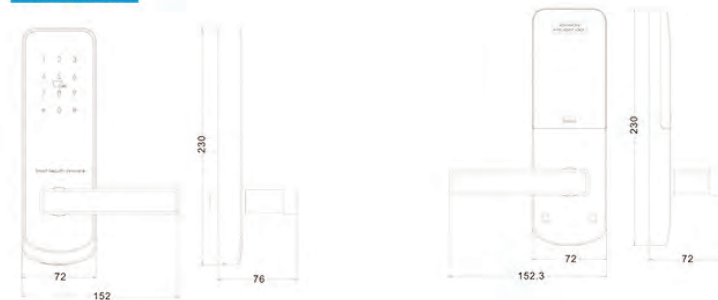

Advanced Technology

Suitable for family, hotel, apartment, homestay and office.



Unlock via BLE



Unlock via time-limited passcode



Unlock via IC card



WIFI available (with gateway)



Unlock via mechanical key



Automatic lock when the door is closed



Voice prompts



Electronic lock



Emergency power



TT Lock App



TUYA wifi solution

A220 series



A220 Series Deadbolt Lock

Parameters :

- Patent design, designed by Italy engineer
- 5# Zinc alloy lock panel
- Satin polish or black nickel treatment
- Acrylic reader with 12 digits passcode
- Work with BLE app, passcode, IC card and mechanical key
- America type cylinder with high security mechanical keys
- Auto lock and auto unlock with 60/70 adjustable deadbolt
- Perfect choice to replace the old locks without extra holes.
- Widely used for wood door or replace the knob locks.

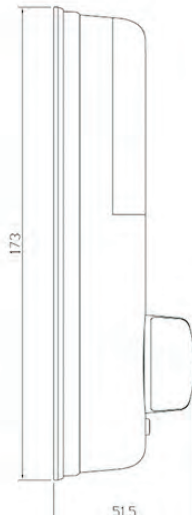
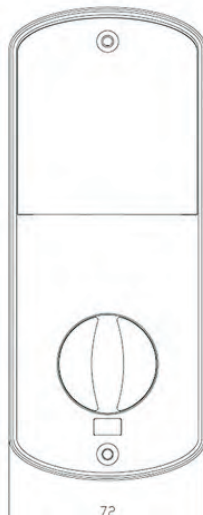
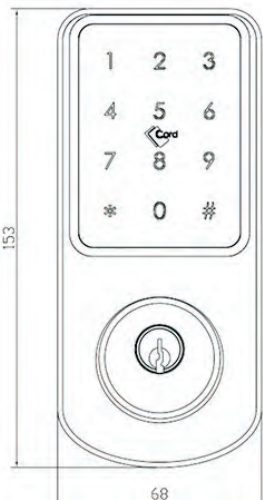

D6

Smart Knob Lock

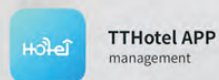

Material:	Zinc alloy
Surface Finishing:	Electroplated
Plate Size:	L70 X W60mm
Unlock Way:	App, Password, Fingerprint, Card, Wristband or Key
App Name:	TTLock App or Tuya App
Support System:	IOS7.0 or Android 4.4 or above
Power Supply:	4pcs AA alkaline batteries
Mortise:	Adjustable single latch (60/70mm)
Color:	Satin Finish / Black Nickle / Antique Copper / Gold
Working Temperature:	-25~70 degree
Apply Door Thickness:	35~65mm
USB Back Up Power:	Yes
Application:	Office, Apartment, Home, School
Applicable For:	Wooden or Metal door

D8

ROUND HANDLE WITH ALLOY TECHNOLOGY

合金工艺 圆润把手

握感舒适，符合人体工学/精致时尚



S118

SPLIT HOTEL LOCK



TTHOTEL



TTLOCK



TUYASAAS



S118 series



PARAMETERS

- Mechanism: 304# reader, front/back panel and handle
- Available to choose leather handle with solid structure
- Unlock way: Mifare card or mechanical key
- Power supply: 4xAA alkaline battery(DC6v)
- Static current: 25uA
- Dynamic current: < 150mA
- Working temperature: -20~45 degree
- Working humidity: 20~95%
- Battery life: Normal open: 15000 times
- Low power alarm: when power is less than 4.8v, there is di-di-di beep,
- Available door thickness: 40~65mm
- Suggest usage: wood door



Password Unlock



IC card Unlock



APP Unlock



TTLock Version



E300P Series
BLUETOOTH DIGITAL LOCK



TT Lock App

E300P Series
BLUETOOTH DIGITAL LOCK

Parameters :

- Classical design Bluetooth lock
- Unlock by Bluetooth APP/IC Card/Passcode or mechanical key
- 304# stainless steel material for lock handle and cylinder cover
- Work with ANSI mortise with 500000 times lifespan
- Free handle design to avoid the artificial damage
- Widely used to replace the apartment or office
- Available to change to Bluetooth hotel lock for hotel use.
- Support BS system with card encoder for management(Hotel version only)
- Emergency mechanical key, no worry for the unlock if there is no power

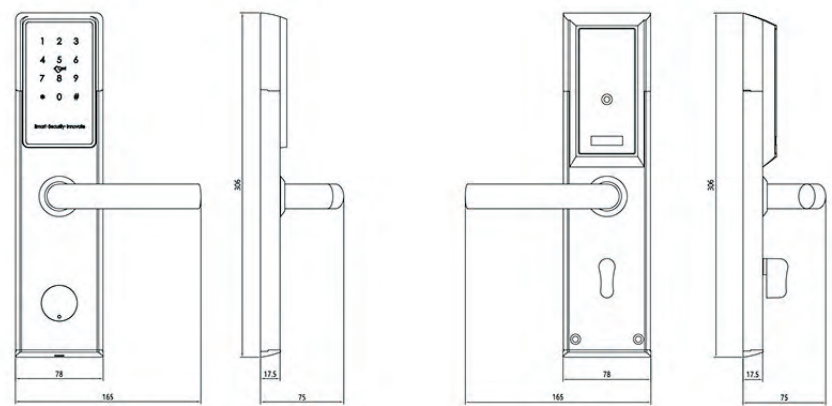

E280P Series

BLUETOOTH DIGITAL APARTMENT LOCK



E280P-SS Satin Finish(70 ANSI Mortise)



TT Lock App

E280P Series



PARAMETERS

Mechanism: 304# front/back panel and handle
304# cylinder cover and handle collar ensure the use under high humidity area
Unlock way: IC card/Mobile APP/password or mechanical key
Power supply: 4xAA alkaline battery(DC6v)
Static current: 25uA
Dynamic current:< 150mA
Working temperature:-20~45 degree
Working humidity: 20~95%
Battery life: Normal open: 15000 times
Low power alarm: when power is less than 4.8v, there is di-di-di beep, then you can still open 150 times.
Audit trial: 990 latest records include the mechanical key
Available door thickness: 40~90mm
Available mortise: ANI mortise and 60-68 security mortise
Suggest usage: wood door

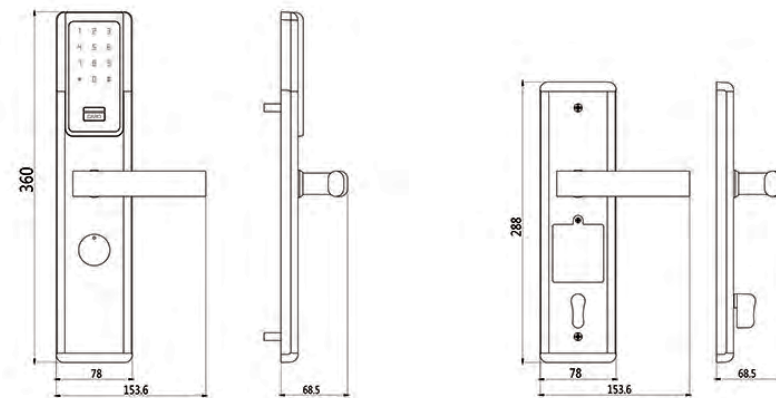

E901CPseries

Slim Design

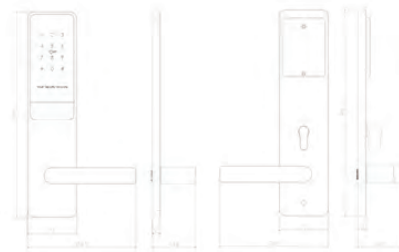

E901CPseries

Slim Design

Parameters:

- Classical design Bluetooth lock
- Unlock by Bluetooth APP/IC Card/Passcode or mechanical key
- Solid Aluminium material for panel and handle
- Work with ANSI mortise with 500000 times lifespan

- Free handle design to avoid the artificial damage
- Widely used to replace the apartment or office
- Available to change to Bluetooth hotel lock for hotel use.
- Support BS system with card encoder for management(Hotel version only)
- Emergency mechanical key, no worry for the unlock if there is no power

- Hotel
- TTHOTEL
- TTLOCK
- tuya
- TUYASAAS



E600P Series

BLUETOOTH DIGITAL APARTMENT LOCK



E600P Series



E600P-SS Satin Finish

PARAMETERS

Mechanism: 304# front/back panel and handle
Sliding cylinder cover and 304# handle collar
Unlock way: IC card/Mobile APP/password or mechanical key
Power supply: 4xAA alkaline battery(DC6v)
Static current: 25uA
Dynamic current: < 150mA
Working temperature: -20~45 degree
Working humidity: 20~95%
Battery life: Normal open: 15000 times
Low power alarm: when power is less than 4.8v, there is di-di-di beep, then you can still open 150 times.
Audit trail: 990 latest records include the mechanical key
Available door thickness: 40~90mm
Available mortise: ANI mortise and 60~68 security mortise
Suggest usage: wood door

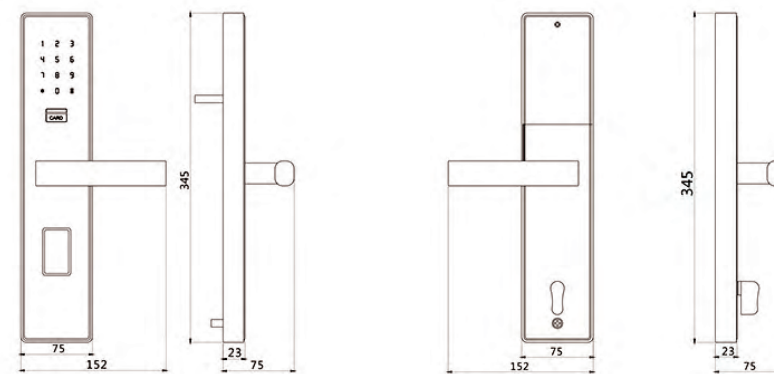

Front Door Type Smart Lock



R5 Fingerprint Lock



Wooden Door Metal Door Glass Door with Frame

Parameters :

Material:	Aluminum Alloy+acrylic
Surface Finishing:	Spray paint
Plate Size:	L156×W59×H35mm (Front) L100×W176×H36mm (Back)
Unlock Way:	App, Password, Fingerprint, Card, Wristband or Key
App Name:	TTLock App or Tuya App
Support System:	IOS7.0 or Android 4.4 or above
Power Supply:	4pcs AA battery
Mortise:	No
Color:	Black Nickle
Working Temperature:	-25~55 degree
Apply Door Thickness:	30~70mm
USB Back Up Power:	Yes
Application:	Apartment, Home, School
Applicable For:	Wooden or Metal door



Bluetooth Access Control

K2/K2F

IP66



House
113



Hotel



Company



Airport



Hospital



TTLOCK BLUETOOTH SOLUTION



Could be used for outdoor condition,
temperature range from -25~55 degree



Fast card reading, easy to operate
Card capacity:20000pcs



This gives users and system administrators
the capability to send or receive a mobile
key to open any door or gate with TT lock APP

Parameter:

Model:	K2/K2F
Dimensions :	W79mm x H125mm x T15.5mm
Material :	Aluminum frame/Tempered glass panel
Communication :	Bluetooth 4.1
Supporting systems :	Android 4.3/IOS7.0 above
Stand-by current :	≈5mA
Operating current :	≈1A
Power supply :	12V
Unlocking time:	≈1.5S
Waterproof level :	IP66
Card capacity:	20,000 Cards
Fingerprint capacity*:	120

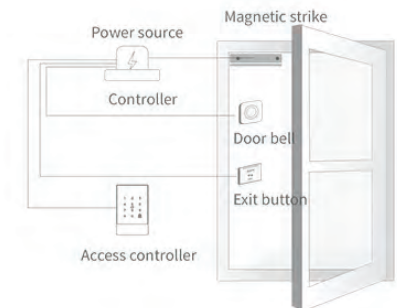

Safe and reliable

You can do it with wet hands

Capacitive high sensitive touch induction
safety waterproof leakage

In-wall Touch Control WiFi Switch

EU style



- Sensitive Touch
- Mobile Control
- Timing Function
- Sharing
- Overload Protection

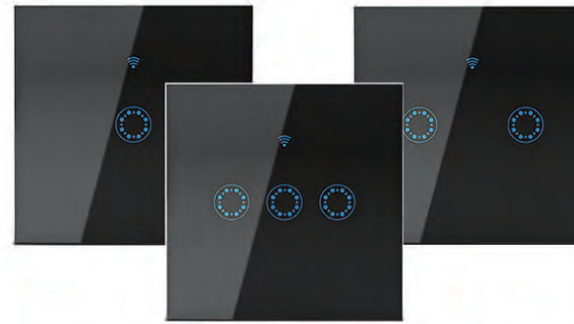

- Alexa
- Google Assistant
- ANDROID APP ON Google play
- Available on the iPhone App Store

1 Gang

3 Gang

2 Gang



- User
- Timing
- Voice Control
- Mobile Control



Need to clear before order

Tuya version

“Smart life” App

1. Color

Black or White?

2. How many gangs

1 Gang, 2 Gang or 3 Gang?

3. Switch version

Single wire switch version

need to add capacitance, usually for old wire

Normal version (live wire + neutral wire)



In-wall Touch Control WiFi Switch

US style



2 Gang



Sensitive Touch



Mobile Control



Timing Function



Sharing



Overload Protection



WiFi touch switch



Works With
amazon alexa



Works with
Google Assistance



3 Gang

Tuya version

“Smart life” App



Need to clear before order

1. Color

Black or White?

2. How many gangs

1 Gang, 2 Gang or 3 Gang?

3. Switch version

Single wire switch version

need to add capacitance, usually
for old wire

Normal version (live wire + neutral wire)



1 Gang

ENERGY SAVING SWITCH

The energy saver is specially designed to be used as power switch in the hotels, home, office, pubs, etc and suitable for Mifare/RF card to control the power with high security. It can save about 40% power consumption in your daily use.

Use method: You can insert one card into the switch to get the power, the signal light will show red. Upon drawing out the card, the power will be off after 15 seconds.



Champagne gold

PARAMETERS

Working voltage: AC220V \pm 10%
Working current: 40A
Rated power: 7000W
Time delay: 15 seconds
Dimension: 86mm \times 86mm
Working temperature: $-40^{\circ}\text{C} \sim +50^{\circ}\text{C}$
Working humidity: RH 10%~90%;
Material: flame-retardant PC.
Color: White/Golden/Grey/Black

3 years warranty

Before order, need to confirm



Grey



White



Black

* Color

- White Black
 Grey Champagne gold

* Frequency

- 125Khz (low) 13.56Mhz (high)

* Voltage

- 220V 110V

* Current

- 40A 60A

* OEM logo

- Yes No

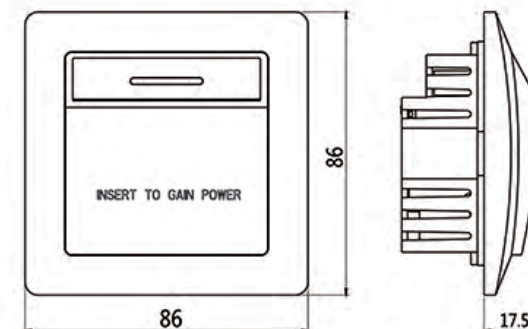

Mechanical Socket (PC material)

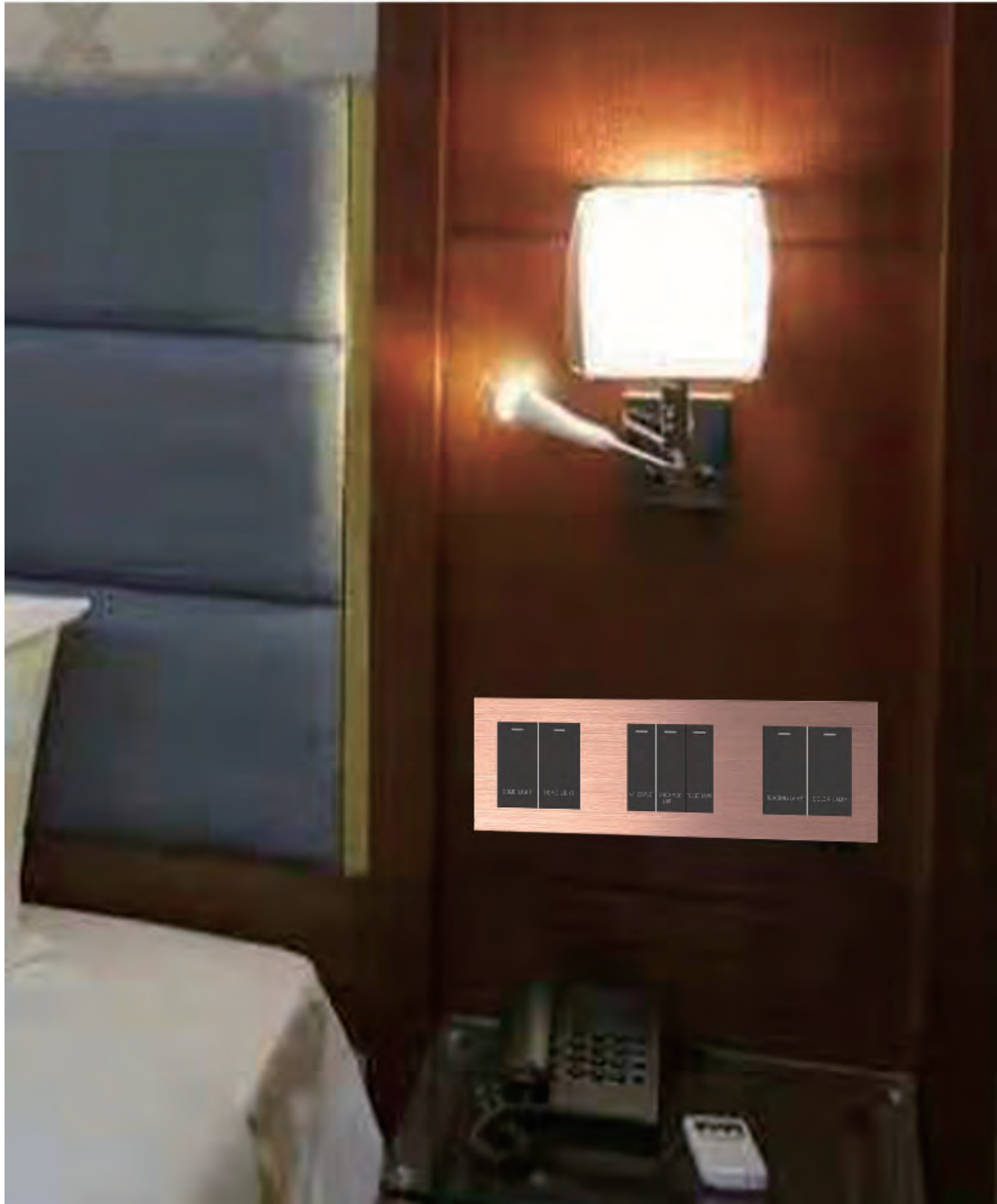

Big button



1 button

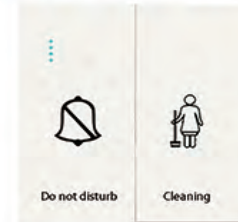

2 buttons



3 buttons



Gery



Black

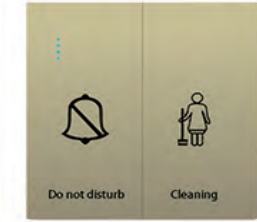

Gloden

Small button

- OEM logo
- OEM signal
- OEM socket quantity
- OEM socket style



Combined sockets is based on your requirements





Thank You